

# Company Presentation

May 2024

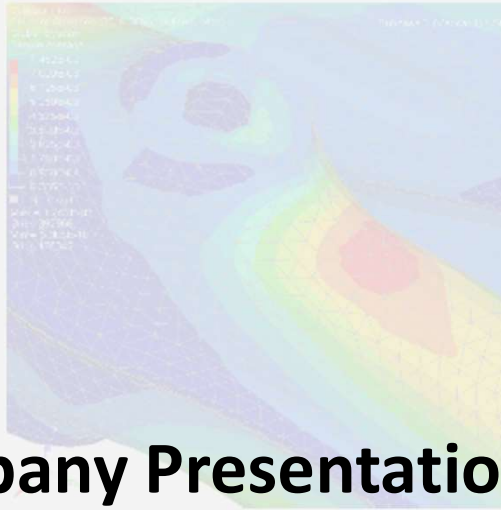

# Engineering Capabilities

- Design to Validation

## Design

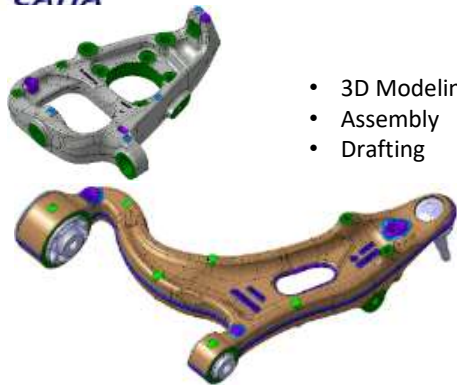

- 3D Modeling
- Assembly
- Drafting

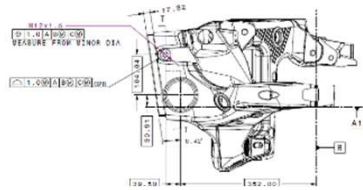

## Analysis

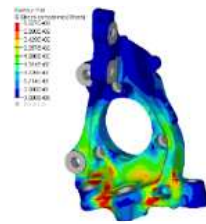

- Linear
- Non-Linear / Contact
- Topology Optimization
- Multi-axial Fatigue
- Road Load Events

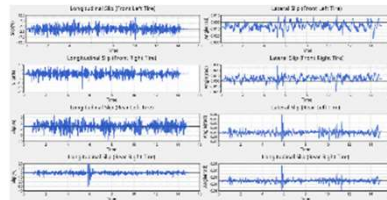
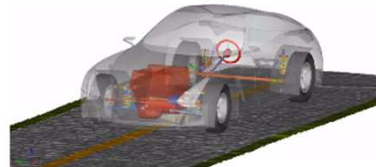
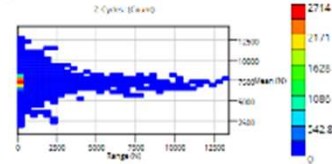

## Process Simulation

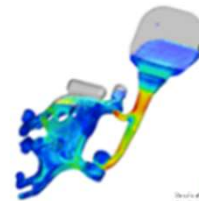
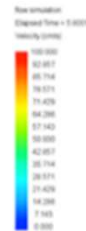

- Low Pressure
- Gravity
- High pressure
- Forging
- CAM

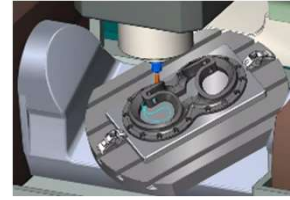
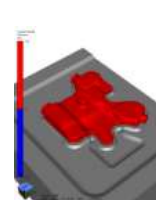
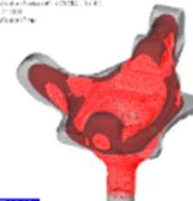

## Validation Testing

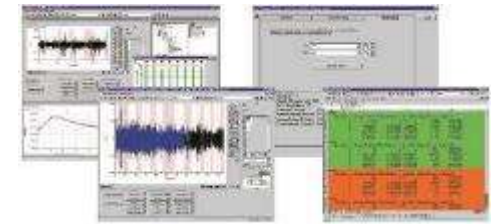

- RLDA Processing
- Fatigue / Strength
- Stiffness



# Facilities

## France

### Plant

1388 Rue Adrienne Bolland 42160 Andrézieux-Bouthéon – France

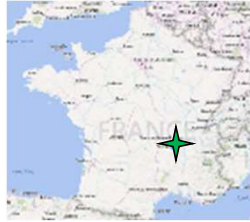

45 min from Lyon Airport (LYS) & Lyon High Speed Train Station



5,000 m<sup>2</sup>



Main Processes	Main Equipment	
Gravity Permanent Mold	• 2 x 6 Station Gravity Tilt Turntables	• 3 Bosello ADR X-Ray Inspection Cells
Cast Forge Process	• In-line Gravity Tilt	• 2 Solution Heat Treat Tunnels
PCPC Casting Process	• 3 Low Pressure PCPC Casting	• 4 Aging Batch Furnaces
T6, T5 & T4 Heat Treatment	• 2 Decoring Stations	• 4 trimming press
Machining & Assembly	• 1700- & 1100-Tons Forging Presses	• Metallurgy Lab
	• Automated Finish Lines	• Assembly line + Assembly Press
	• Automated Sawing Stations	• 5 and 4 axis - CNC Machines
		• 1 FPI Line

### Quality

IATF 16949

ISO-14001

Ford WCMS & CQI9

## 89 Employees

# Anderton Castings

- Layout

*Building 5,000 m<sup>2</sup>*

*Land 37,704 m<sup>2</sup>*

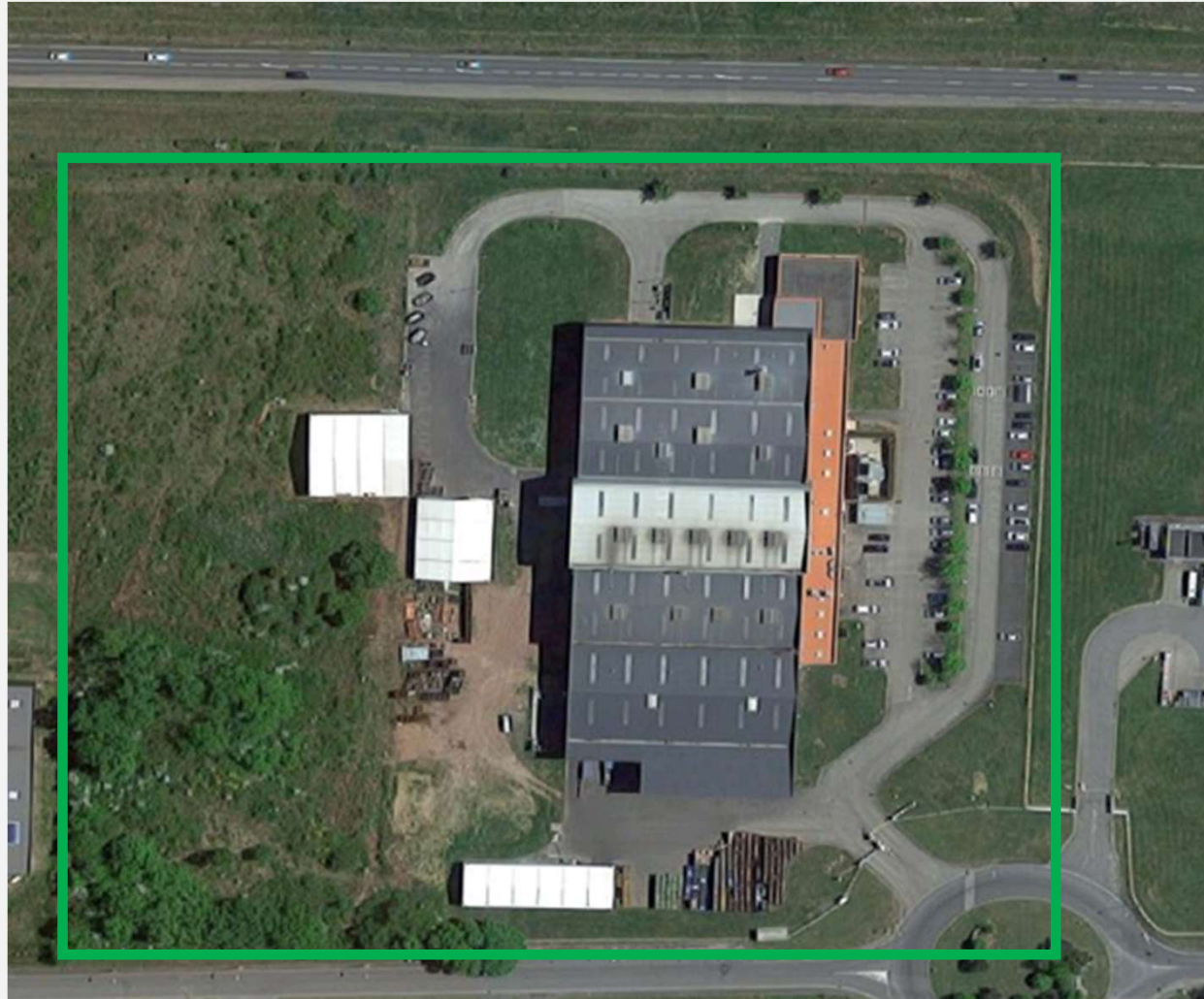

# Anderton Castings

## Layout

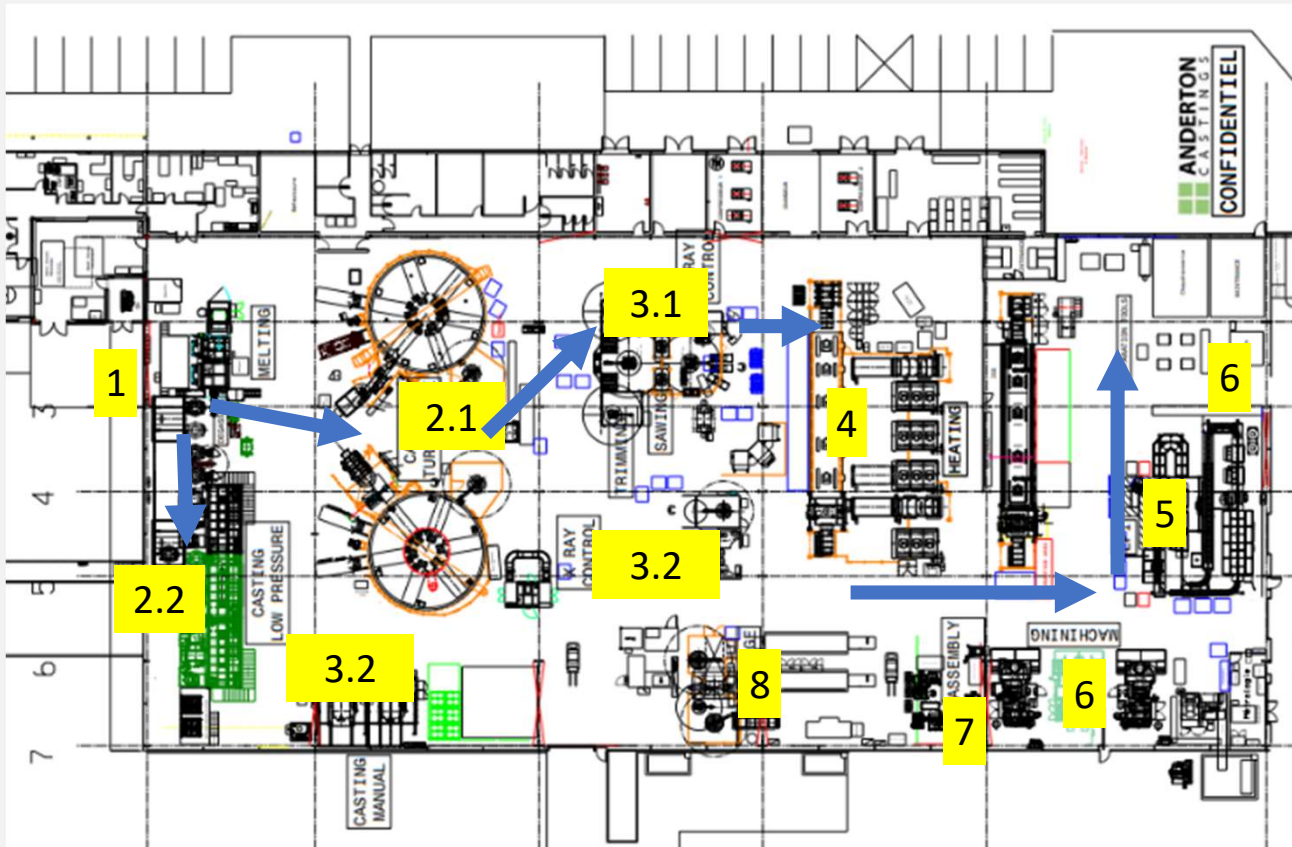

LAYOUT	
1	Melting
2.1	Turntable casting
2.2	Low pressure casting
3.1	Finishing cell
3.2	Finishing equipment
4	Heat Treatment
5	LPI crack detection
6	Machining
7	Assembly
8	Forging

### Turn over

- **2022 – 13 M€**
- **2023 – 26 M€**

### Customers

- **Streparava**
- **Benteler**
- **GM**
- **Canoo**
- **Karma**

# Anderton Castings

- Main Equipment - France



Low Pressure (PCPC) Line



Fully automated Gauss Carousels



X-ray inspection  
Automatic Defect Recognition



Automated De-coring, Trimming & Sawing

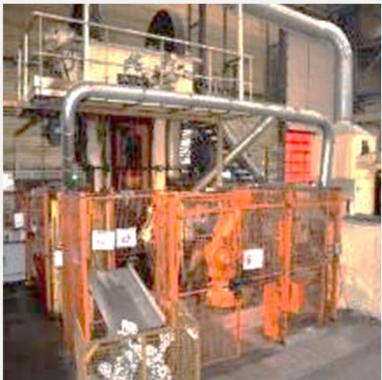

Automated 1100 & 1700 tons  
Forging Presses



Automated Solution Heat Treat Tunnels



5 axis Dual Spindle Machining



Assembly line

# Anderton Castings France



## Measurement And Testing



Mechanical Properties Testing



Metallurgical Samples Preparation



In house Validation Testing



Microstructure Analysis



CMM Room

- Spectrometry
- Density & K-Mold
- Ultrasound Testing





# Anderton Castings

## Products Selection

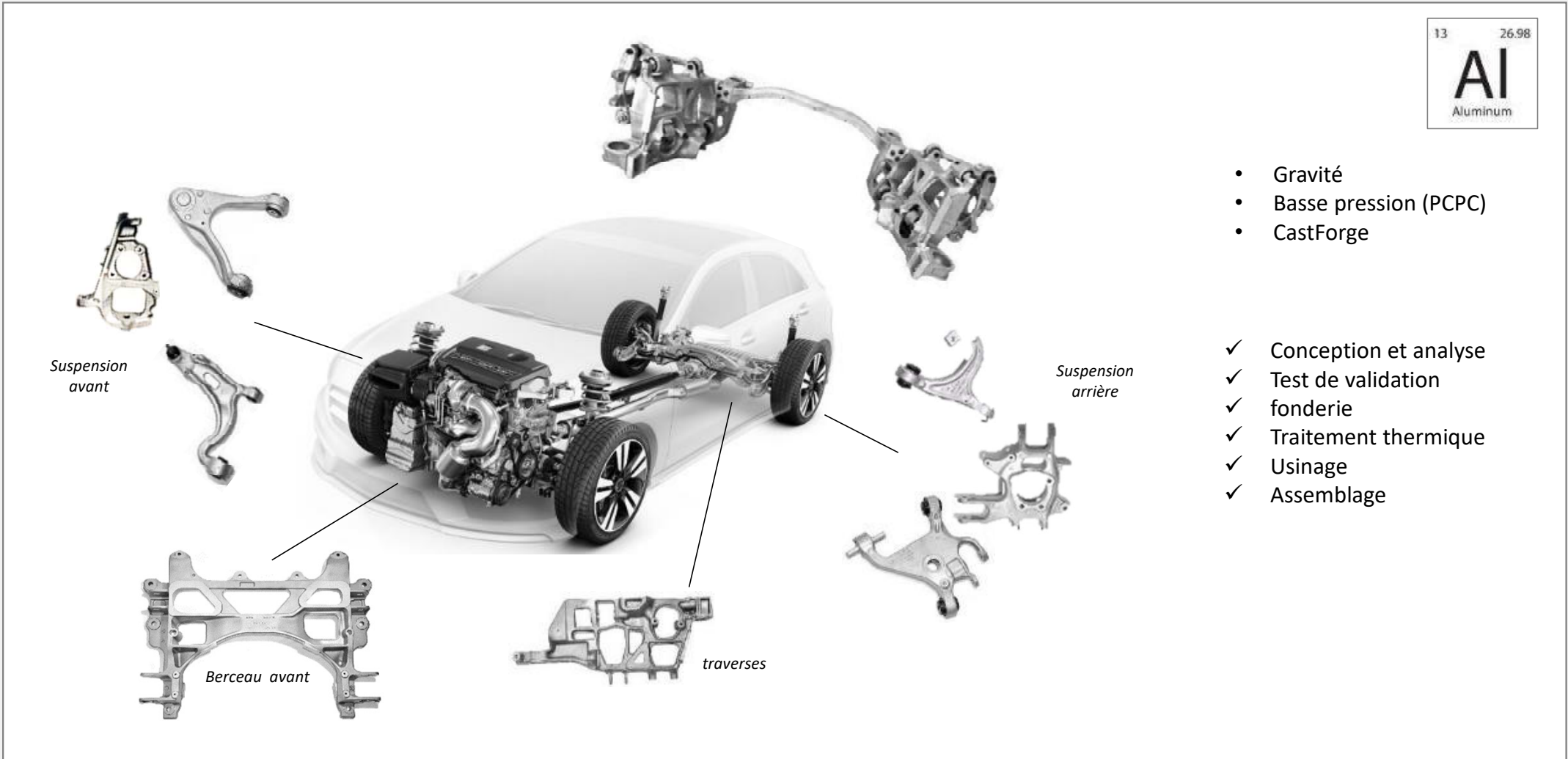

# Anderton Castings

- Products Selection – Gravity and PCPC (low Pressure)

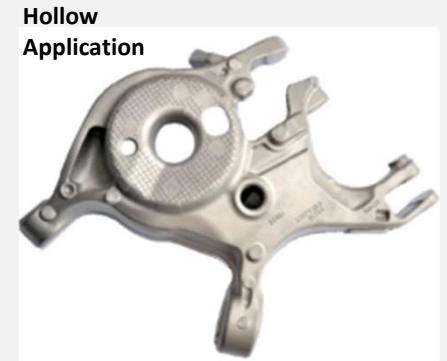
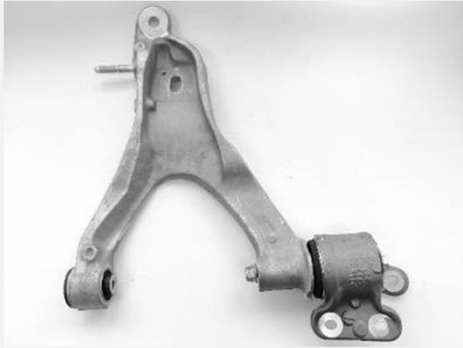

# Anderton Castings

- Product Selection - Low Pressure PCPC and CastForge

